



Operating instructions

(Translation of the original operating instructions)

ZING

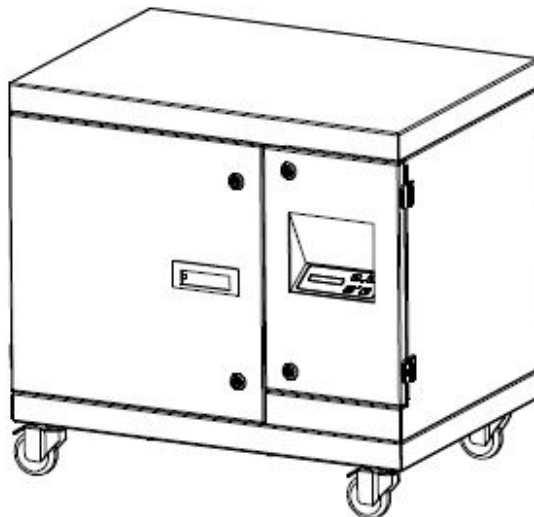

Table of contents

1. General	3
2. Description of the system elements	4
2.1. Illustration of the system elements	4
2.2. Functionality of the system	5
2.3. Intended use	5
3. Safety instructions	5
3.1. Definition of the hazard symbols	5
3.2. General safety instructions	6
4. Storage, transport and installation of the device	6
5. Commissioning	7
5.1. Connecting the suction line and exhaust air line	7
5.2. Electrical connection	7
5.3. Connection of the vacuum pump (optional)	8
6. Operating the system	9
6.1. Explanation of the operating elements	9
6.2. Connection of an external control	9
7. Maintenance	10
7.1. Reset to maintenance state	10
7.2. Replacing the particle filter	11
7.3. Replacing the activated carbon cassette	12
7.4. Replacing the pocket filter	14
8. Dismantling / Disposal	15
9. Diagnostics and troubleshooting	16
10. List of spare parts	17
11. Technical data	17
12. EC declaration of conformity	18
13. Training protocol	19
14. Maintenance intervals	20

14.1. Usage-related maintenance	20
14.2. General maintenance	20
14.2.1. Visual inspection of the device	21
14.2.2. Functional test of the device	21
14.2.3. Electrical test of the electrical lines and earthing connections	22

1. General

Congratulations on purchasing the product from TEKA.

Our engineers ensure that our devices reflect the state of the art through continuous development. Nevertheless, misuse or misconduct can endanger your safety. Please observe the following for a successful use of the device:

	<p>Only authorised and instructed personnel can carry out transport, operation, maintenance and repair of the device. The operator must ensure that the operating personnel take note of these instructions.</p> <p>Please read these instructions before operating the device, and observe the safety precautions to avoid injury!</p> <p>Store this manual in a safe place! These instructions are to be regarded as a component of the product!</p> <p>Adhere to all product notes!</p> <p>Modifications or conversions that the operator carries out at the device without the consent of the manufacturer, can lead to new safety hazards or to the loss of warranty claims.</p> <p>Observe the manufacturer's instructions. Contact the manufacturer in case of any uncertainty: Tel: +49 2863-9282-0 E-mail: info@teka.eu</p>
---	--

2. Description of the system elements

2.1. Illustration of the system elements

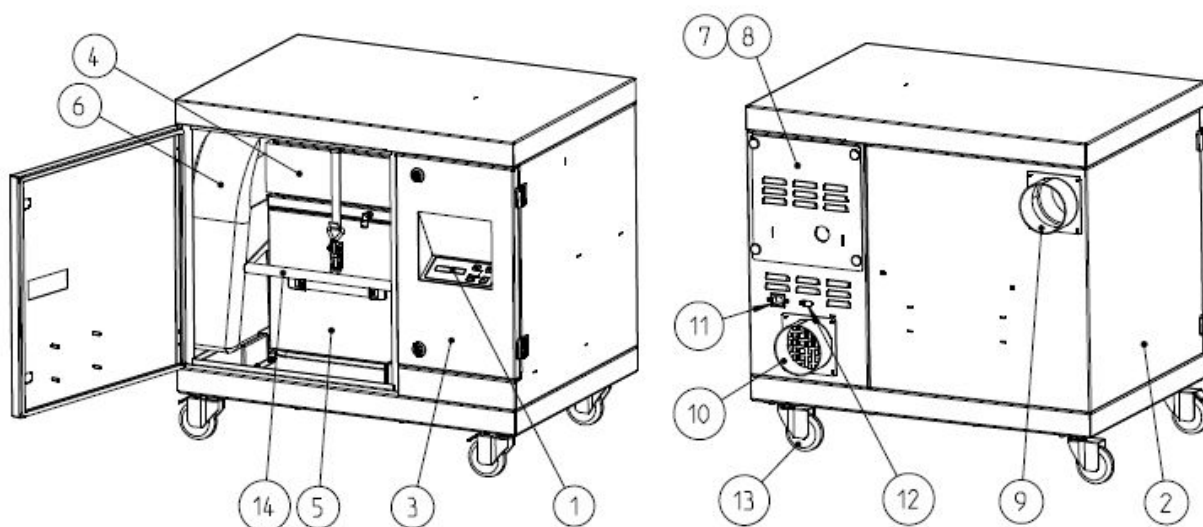

Z.Nr. 08461705

Pos.1	Operating panel of the control	Pos.9	Suction nozzle
Pos.2	Filter housing	Pos.10	Exhaust air nozzle
Pos.3	Turbine housing	Pos.11	Connection for mains cable
Pos.4	Particle filter	Pos.12	Connection for external control unit
Pos.5	Activated carbon cassette	Pos.13	Swivel castor
Pos.6	Pocket filter	Pos.14	Lifting handle of the lifting device
Pos.7	Maintenance door for vacuum pump		
Pos.8	Vacuum pump (optional)		

2.2. Functionality of the system

The filter unit serves to suck off and filter polluted air (according to the intended use). First of all, the coarse particles are separated in the pocket filter in the filter section of the unit. The subsequent particle filter cleans even fine smokes and dusts. The activated carbon filter absorbs gases and unpleasant odours. An automatic filter monitoring indicates when a cleaning or a replacement of the filters is necessary.

2.3. Intended use

The filter unit is intended for extraction and filtration of fumes that result from lasers.

	WARNING
	Improper use can damage parts and be a danger to life and limb! The device must not be used for the extraction of oil-laden welding fume, explosive dust and gases, hybrid mixtures, glowing or burning substances, gases, water, etc. The device must not be operated in explosive zones.

3. Safety instructions

3.1. Definition of the hazard symbols

The device is constructed according to the state of the art and the recognised safety regulations. Nevertheless, during use threats to life and limb of the user or other persons may arise. The impairment of the machine or other property are also possible. In these instructions we warn by using corresponding indications.

	WARNING
	WARNING These instructions are made in case of risks that can lead to <u>injury or death</u> .

	CAUTION
	CAUTION These instructions are made in case of risks that can lead to <u>injury</u> .

	NOTICE
	NOTICE These instructions are made in case of risks that can lead to <u>material damages</u> .

	Information notes are no hazard warnings; they call attention to useful information.
---	--

3.2. General safety instructions

	WARNING
	<p>Dangers arising from improper use / unauthorised operations. The operator must ensure that their authorised personnel are familiar with all the safety indications in this manual in advance. The operator is responsible for ensuring that all work is carried out by authorised and qualified personnel. We therefore recommend using the training protocol on the last page for that purpose (see chapter "Training protocol"). Laymen are allowed to operate the device after having received the necessary instructions. But they are not allowed to carry out any installation, repair or maintenance work.</p> <hr/> <p>Dangers arising from fire. In case of fire, if possible, switch the unit immediately off or disconnect it from the power supply. Fire extinguishing measures which the operator is obliged to determine beforehand must be initiated immediately.</p>

	WARNING
	<p>Dangers arising from electricity. The operator must ensure that electrical plants and equipment are only built, modified and maintained by a qualified electrician or under the direction and supervision of a qualified electrician. Do not work on components if you are not sure that these are disconnected. If necessary, disconnect the device from the electric power supply and secure it against unauthorized restarting.</p>

4. Storage, transport and installation of the device

	WARNING
	<p>Risk of injury from tilting or unmounted components when stored or transported. The device must be secured against tilting and slipping when it is stored or transported. Do not stand under or next to the floating load. Lift trucks, forklift trucks and transport cranes must have a sufficient minimum load bearing capacity. Pay attention to uneven grounds during the transport. Avoid jerky pushing.</p> <hr/> <p>Dangers arising from titling or functional impairments at its destination. The unit may only be set up on a suitable surface. The surface must be vibration-free and horizontal. The operator must check the bearing capacity of the surface. As soon as the unit has reached its intended destination, the brakes of the castors must be activated.</p>

	NOTICE
	<p>Damage or functional impairment of the unit due to climatic influences. The unit must be stored in a dry place and protected against moisture during transport. As a matter of principle, the filter unit is not designed to be installed outside.</p>

5. Commissioning



WARNING

Dangers arising from a defective condition of the unit.

Make sure that the measures described in this chapter are completed before the commissioning of the unit. All doors of the unit must be closed and all necessary connections must be attached before turning the unit on. Do not operate the unit if any components are defective, missing or damaged. Check the orderly condition of the unit before switching it on. The unit must not be operated without a filter element.



NOTICE

Damaged supply lines.

Make sure that the supply lines are protected against damage by forklift trucks and similar events. Protect all supply lines from heat, moisture, oil and sharp edges.

5.1. Connecting the suction line and exhaust air line

For extracting the contaminated air, a suction line must be connected to the suction nozzle (see chapter 2.1).



CAUTION

Danger for the respiratory tract arising from polluted ambient air. Dust deposits in the suction pipe are possible.

Only operate the system if the necessary suction line is fitted.

If the air shall be directly sucked off by an upstream machine, the suction line must be connected to the capture opening of the upstream machine.

The exhaust air pipe must be attached to the exhaust nozzle (see chapter 2.1).

5.2. Electrical connection



NOTICE

Electric malfunction possible in cause of an incorrect power supply.

Pay attention to the admissible supply voltage. Please observe the specifications on the type plate.

- Connect the mains cable (see chapter 2.1) to the power supply.

5.3. Connection of the vacuum pump (optional)

The vacuum pump is an optional accessory of the laser. In order to integrate the pump, please observe the indications of the laser / vacuum pump manufacturer.

For integration in the device, unscrew the knurled screws at the maintenance door (see chapter 2.1). Pull out the maintenance door with the plug-in plate. Install the pump on the plug-in plate. The pump is connected via the mains connection at the interior. The pump can be controlled separately (menu #13 of the control unit).

6. Operating the system

6.1. Explanation of the operating elements

 Control functions, setting options for programs, menu navigation, error messages, etc. are described in the enclosed operating manual of the unit control. There is also an explanation of the elements of the control panel.

6.2. Connection of an external control

There is the possibility to control the unit from extern. For this purpose, a connection is provided on the unit (see chapter 2.1).

Connection plug type:	“Sub-D9”
Number of pins:	9

Pin-Nr.	Designation	Explanation
1, 2	Start contact	In order to switch on the filter unit, a contact has to be connected between pin 1 and pin 2. The unit is switched out when the contact is opened.  When the follow-up time is activated, the unit switches off after the preset period of time.
3, 4	External message “Fault”	Pin serves for the evaluation of an fault indication. (NO: normaly open)
5, 6	External message “Operation”	Pin serves for the evaluation of the operational control. (NO: normaly open)
7	Increase of the speed of the turbine <i>(option)</i>	In order to increase the performance of the turbine, a contact has to be connected between pin 7 and pin 2. <i>(optional, and only for units with up to 2 x 1,2kW turbines)</i>
8	Reducing of the speed of the turbine <i>(option)</i>	In order to reduce the performance of the turbine, a contact has to be connected between pin 8 and pin 2. <i>(optional, and only for units with up to 2 x 1,2kW turbines)</i>
9	GND	Internal reference potential (ground, mass)

7. Maintenance



In accordance with national regulations, the operator is obliged to carry out repeat and functional tests. Unless otherwise specified by national regulations, we recommend regular visual inspections and functional tests of the device as described in the chapter “Maintenance intervals”.

 You find the chapter “Maintenance intervals” at the end of the document. The general maintenance (visual inspection, etc.) is also explained there.

In the chapter “Maintenance intervals” there is information on the maintenance intervals of the filter elements. But these are only recommendations. Depending on the application (multi-shift operation, dust generation, ...) it may be necessary for the operator to change the maintenance intervals.

In this chapter the maintenance work which is caused by wear caused during operation is described.

WARNING	
	<p>Work on the open system entails the risk of electrical shock or accidental restart the system. Both pose a danger to life and limb.</p> <p>When cleaning and servicing equipment during the replacement of parts or when changing to another function, set the device to maintenance condition first (see chapter “Reset to maintenance state”).</p> <p>A recommissioning of the device must only occur if it is ensured that the device is functionally equivalent to the original state.</p>

CAUTION	
	<p>Hazards to the respiratory tracts are possible.</p> <p>All maintenance work must only be carried out in well-ventilated rooms and while wearing an appropriate respiratory mask! We recommend: respiratory protection half mask DIN EN 141/143 protection level P3. For all maintenance work ensure a cautious handling of filter elements and components in order to avoid whirling up dust.</p>
	

 The operator is obliged to store and dispose of the collected dust in accordance with national or regional regulations. For all maintenance or cleaning work please refer to the applying environmental regulations. Pollutants and filter elements must be disposed of or stored according to the regulations as well. If you have any doubts, we recommend contacting a disposal contractor in your area.

7.1. Reset to maintenance state

- Switch off the unit. Unplug the mains plug. Secure the unit against unauthorized restarting during maintenance.
- After completion of all maintenance work the unit can be reconnected to the power supply.

7.2. Replacing the particle filter

Replacing the particle filter is necessary when the device control signals the corresponding error. (see chapter "Description of the control elements")



CAUTION

Whirling up dust is possible.

The particle filter is a disposable filter element. Do not try to clean the filter element.

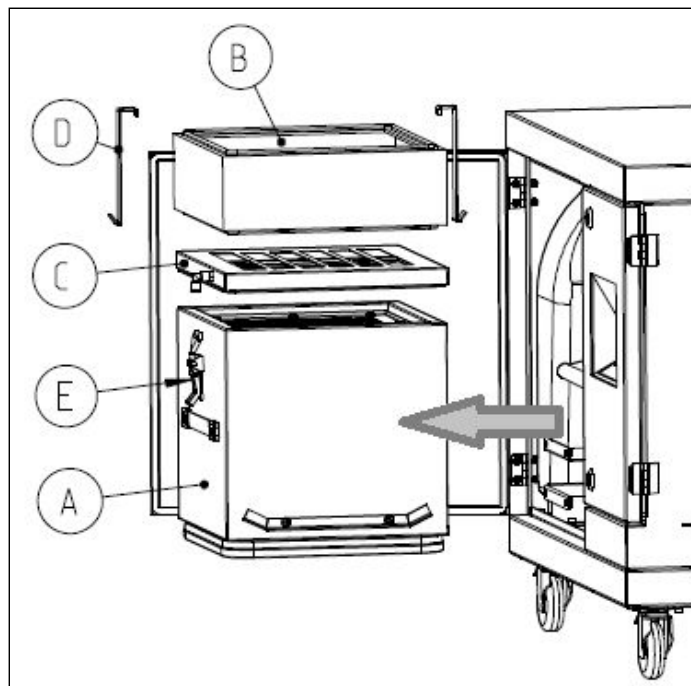

- Open the service door of the filter housing (see chapter 2.1).
- Elevate the lifting device by pulling down the lifting handle (see chapter 2.1).
- Carefully pull the entire filter pack out of the housing.
- Loose the toggle levers (E) and the clamping hooks (D). Take the particle filter (B) and the measure frame (C) from the activated carbon cassette (A). If necessary loose the measure hose from the measure frame.
NOTICE The measure hose must be fixed again at the measure frame after maintenance.
- Replace the particle filter.
NOTICE Only use TEKA spare filters. Otherwise the proper functioning of the unit is not guaranteed.
- Push the filter pack back into the filter housing. Make sure that the filter elements are inserted in the correct order. For this also the clamping hooks (D) must be hooked in again in the particle filter (B) and fixed with the toggle levers (E).
- Lower the lifting device. Close the service door.

7.3. Replacing the activated carbon cassette

The activated carbon absorbs gases and unpleasant odours. The activated carbon has to be replaced as soon as gases appear on the clean air side.

However, at the latest when the main filter of the device is replaced, the activated carbon should be replaced as well. For it is also the pollution of the activated carbon which lowers the (entire) extraction capacity of the filter unit.



CAUTION

Whirling up dust is possible.

The activated carbon cartridge is a disposable filter element. Do not try to clean the filter element.



The saturation degree of the activated carbon is not monitored.

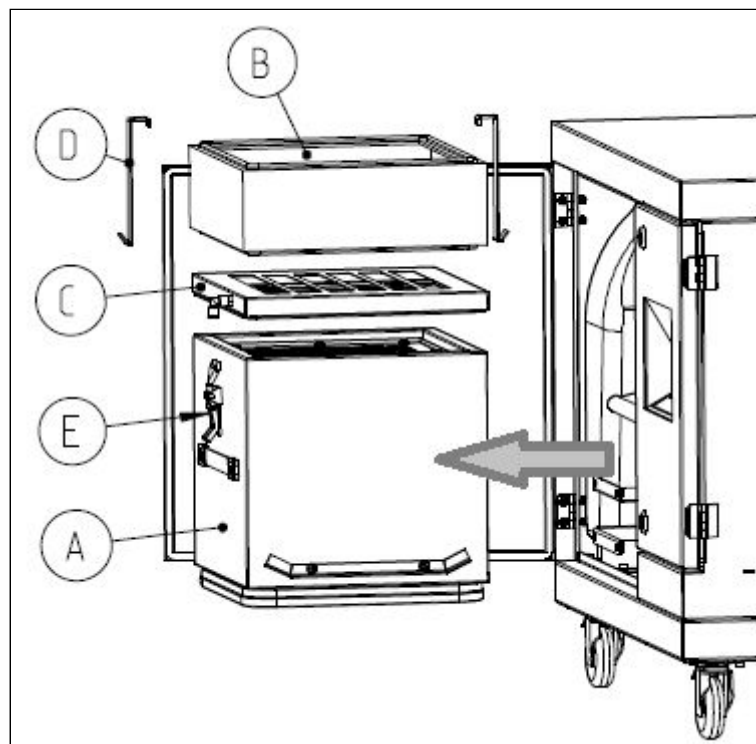

- Open the service door of the filter housing (see chapter 2.1).
- Elevate the lifting device by pulling down the lifting handle (see chapter 2.1).
- Carefully pull the entire filter pack out of the housing.
- Loose the toggle levers (E) and the clamping hooks (D). Take the particle filter (B) and the measure frame (C) from the activated carbon cassette (A). If necessary loose the measure hose from the measure frame.

NOTICE The measure hose must be fixed again at the measure frame after maintenance.

-
- Replace the activated carbon cassette.
NOTICE Only use TEKA spare filters. Otherwise the proper functioning of the unit is not guaranteed.
 - Push the filter pack back into the filter housing. Make sure that the filter elements are inserted in the correct order. For this also the clamping hooks (D) must be hooked in again in the particle filter (B) and fixed with the toggle levers (E).
 - Lower the lifting device.
 - Close the service door.

7.4. Replacing the pocket filter

The pocket filter is installed upstream to the particle filter and separates the coarse particles. This extends the service life of the particle filter.

The pocket filter must be changed after a certain number of operating hours. The time depends on the amount of accumulated dust, and therefore cannot be determined beforehand. At the latest, the pocket filter must be changed when changing the particle filter.



CAUTION

Whirling up dust is possible.

The pocket filter is a disposable filter element. Do not try to clean the filter element.

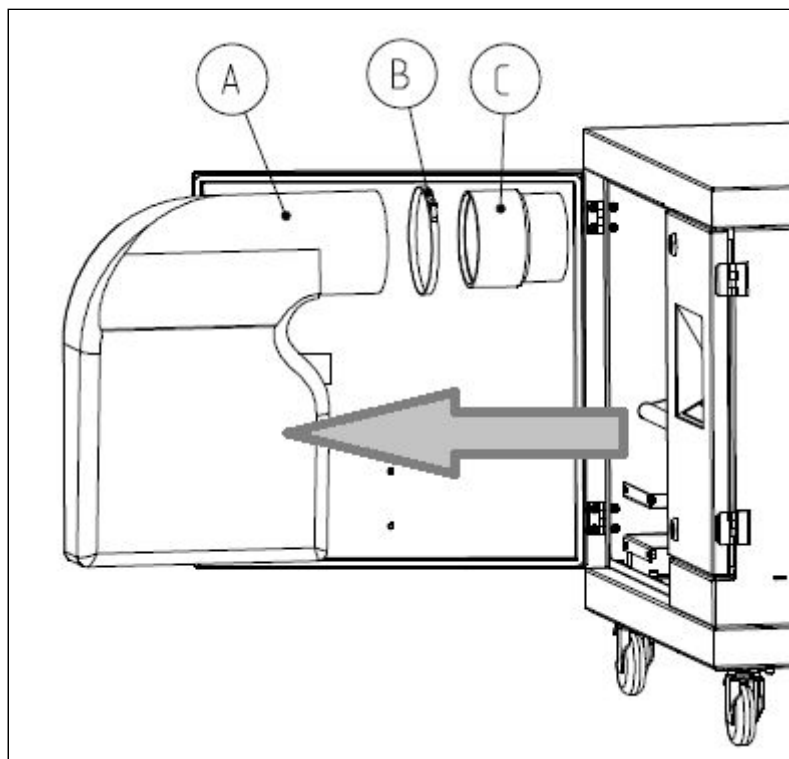

- Open the service door of the filter housing (see chapter 2.1).
- Carefully pull the pocket filter (A) out of the housing. For this also the nozzle (C) must be pulled out.
- Loose the hose clamp (B) for mounting the nozzle (C) at the new pocket filter.
NOTICE Only use TEKA spare filters. Otherwise the proper functioning of the unit is not guaranteed.
- Push the new pocket filter back in the filter housing. For this pull the nozzle (C) again in the opposite nozzle, which is inside the filter housing.
- Close the service door.

8. Dismantling / Disposal

Only authorised personnel may disassemble the machine.

	WARNING
	Dangers arising from electricity. Before the dismantling of the machine it has to be disconnected from the power supply and all supply lines.

	CAUTION	
	Whirling up dust is possible due to the deposited dust. During all work a suitable respiratory protection and protective clothing have to be worn.	

	The operator is obliged to store and dispose of the collected dust in accordance with national or regional regulations.
---	---

9. Diagnostics and troubleshooting

A list of possible system errors is provided in the table.

 Error messages of the control unit are described in the enclosed operating manual of the control unit.

A recommissioning of the device must only occur if it is ensured that the system is functionally equivalent to the original state. Repairs may only be carried out by TEKA personnel or, after consultation with TEKA GmbH, by the personnel authorised by the operator.

Adhere to the instructions in the chapter "Safety instructions" and "Maintenance" when carrying out any repairs. If in doubt, contact our TEKA service department:

Tel: +49 2863-9282-0
E-mail: info@teka.eu

Fault	Cause	Removal
System does not start.	Plug power supply is missing or incorrectly inserted.	Plug connector check power supply / plug in correctly.
	No power at outlet.	Check the mains, remove error if possible.
Dust at the service door of the filter housing.	The door is not correctly closed.	Close the door.
	The seal between the service door and filter housing is damaged.	The seal must be replaced.
	Escape of dust at the hinge.	The hinge must be reoriented or replaced.
Suction power too low (smoke hardly extracted).	Filter element is saturated.	Replace the filter package, dispose of old filter properly!
	Damage at the extraction elements.	Replace the extraction elements.
	Suction line contracted.	Check and fix.
	Exhaust line contracted.	Check and fix.
The system is very noisy.	The suction line or exhaust line are not mounted.	Mount the line.
	The unit is untight.	Check and fix.

10. List of spare parts

Filter element	Article no.
Particle filter "H13" (305x305x100)	100310002
Activated carbon cassette (305 x 305 x 300)	97055
Pocket filter "G4" (125 x 380 x 450)	10099000303
Other parts	Article no.
Hose FLEXTRACT (Ø100 x 800)	511241007

11. Technical data

Supply voltage	V	115 / 230
Frequency	Hz	50 / 60
Type of current	Ph	1
Engine power	kW	0,6
Air flow volume max.	m³/h	170
Negative pressure max.	Pa	15000
Protection class		IP54
ISO class		F
Extraction performance	%	> 99
Width	mm	745
Depth	mm	546
Height	mm	700
Weight	kg	ca. 75
Sound pressure level	dB(A)	68
Allowed ambient temperature	°C	+5 to +35
Allowed max. humidity	%	70

12. EC declaration of conformity

according to the Machinery Directive 2006/42/EG, Annex II, 1 A

TEKA Absaug- und Entsorgungstechnologie GmbH

Industriestraße 13, D-46342 Velen

Tel.: +49 2863-9282-0

E-Mail: info@teka.eu

Internet: www.teka.eu

Designation of the device: ZING

We hereby declare under our sole responsibility that the product mentioned above, from the serial number A18200010011001 resp. P39000010011001 on, conforms to the following directives:

Machinery Directive: 2006/42/EG

Electromagnetic Compatibility: 2014/30/EU

This declaration will become void if the device is exposed to modifications that are not approved by the manufacturer in written form.

Authorized representative for the technical documentation:

TEKA Absaug- und Entsorgungstechnologie GmbH, Industriestraße 13, D-46342 Velen

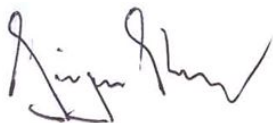

(Jürgen Kemper, managing director)

Velen, 3rd January 2020



13. Training protocol

Designation of the device: ZING

(This form can be used by the operator to document the training of the employees. Training should be performed by authorized personnel only. Refer to the instructions in Chapter "Safety Instructions")

By his signature, the employee confirms that he has been instructed regarding the following items:

Instruction	completed
Description of the device	
Operation and application of the device	
Explanation of the safety instructions	
Behavior in case of fire	
Explanation of the operation elements	
Change and dedusting of the filter elements	
Appropriate disposal	
Maintenance works / Maintenance intervals	

Name of the employee (legible)	Signature

Introduction through (legible):	
Signature:	

14. Maintenance intervals

14.1. Usage-related maintenance

The described maintenances become necessary through the demands of the system operations. The maintenance intervals are recommendations. Depending on the application (multi-shift operation, dust generation, ...) it may make sense for the operator to change the intervals of maintenance, replacing and cleaning.

Maintenance work must always be documented by means of a protocol.

The approach of the maintenance measures is described in chapter "Maintenance".

Maintenance work	Chapter	Maintenance interval	
		recommended by TEKA	determined by the operator
Replacing the particle filter	7.2	The saturation of the particle filter is automatically monitored by the filter unit and thus is not subject to a maintenance interval. The filter unit triggers an alarm when a replacement of the particle filter is necessary.	
Replacing the activated carbon cassette (or check the degree of pollution)	7.3	when odours occur / when replacing the main filter	
Replacing the pocket filter (or check the degree of pollution)	7.4	quarter-annually	

14.2. General maintenance

The described maintenances are independent from the demands of the system operations.

The operator is obliged to carry out repeated inspections and functional tests according to national regulations. If not otherwise covered by national regulations, the described maintenance intervals must be respected.

Maintenance work must always be documented by means of a protocol.

Maintenance work	Chapter	Maintenance interval
Visual inspection of the device	14.2.1	weekly
Functional test of the device	14.2.2	monthly
Electrical test of the electrical lines and earthing connections	14.2.3	annually

14.2.1. Visual inspection of the device

Visual inspection: Observation that there are no visible safety-related defects.

	WARNING
Danger arising from the ready to operate condition of the device. Follow the procedure as described in the chapter "Set to maintenance state".	

The following steps must be carried out in the course of the visual inspection:

- Check if all required pipeline elements, cable connections and hoses are connected to the filter unit
- Ensure that all parts are firmly connected.
- Check all connection points of the filter unit for escaping dust.
- Check all metal parts for corrosion or damages / changes of the coating.
- Check the inner filter area and the filter housing.
- Visual inspection of the control and operating elements as well as the outside running cables for damages.

14.2.2. Functional test of the device

	NOTICE
Possible material damage due to faulty condition of the unit. Carry out a visual inspection before the functional test of the device as described in the previous chapters. The work as described in the chapter "Commissioning" must be finished.	

The following steps must be carried out in the course of the functional test:

- Switch on the device.
- Pay attention to failures or error messages of the control unit. Also refer the separated operating manual of the control unit.
- Pay attention to extraneous noises or vibrations during the device's operation.
- A functional test should always be carried out with a connected / producing machine tool. Check if the collection of the fume or dust is sufficient. (Visual inspection).

14.2.3. Electrical test of the electrical lines and earthing connections

	WARNING
Danger arising from electricity. The operator is responsible for ensuring that all work on electric components is carried out by authorised and qualified personnel.	

The device is subject to regular electrical checks by the operator of the device, and are subject to national standards of the different countries.

The here recommended maintenance interval complies with the in Germany applying "Regulation 3 of the German Social Accident Insurance - Electrical plants and equipment" (formerly known as BGV-A3).

The check must only be carried out by a qualified electrician or a person trained in electrics using suitable measuring and test devices. The scope of testing and the methods must be in line with the respective national standard. All contacts in the control cabinet must be checked for tight fit, and must be readjusted if necessary.